

TOUCH FX

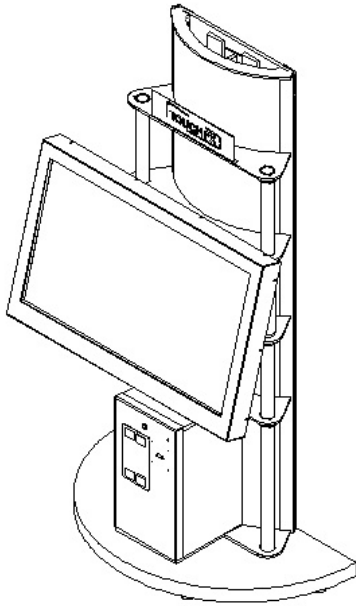

TFX1

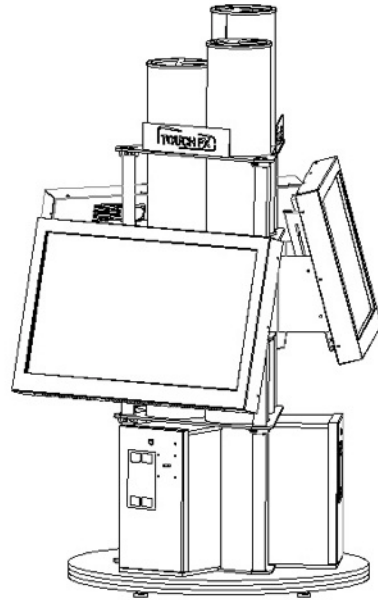

TFX3

Operation & Service Manual

***Read this manual before use**



ADRENALINE AMUSEMENTS

General Remark

If you encounter any difficulties or if you need support on how to update and/ or install your TouchFX product, we invite you to contact your local distributor or reach us at info@adrenalineamusements.com or by calling our support line +1.450.932.4205

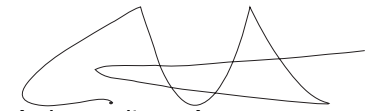

Adrenaline Amusements Team

Table of Contents

Chapter 01 – Introduction

Preface	04
Safety	05
FCC Notice (United States)	06

Chapter 02 – Product Features

Features	07
Voltage	07
Dimensions	07

Chapter 03 – Installation

Machine Installation	08
----------------------------	----

Chapter 04 – Operators' Menu & Game Setup

Operators' Menu & Game Setup	09
Product Default Settings	09

Chapter 05 – Service & Repair

Computer	11
Trouble Shooting	12
Screen	12
Calibration	12
Window booth Error	13
General	14
Replacement Part	
Fluorescence Tube Replacement	15
Screen Assembly	16
Door Assembly	17

Chapter 06 - Diagrams & Schematics

Control Card	18
Wiring Diagrams	19

Chapter 1

Preface

Please read this page before preparing your TouchFX product for game play

The following safety instructions apply to all game operators and service personnel. Specific warnings and cautions will be included throughout this manual.

Use the following safety guidelines to help protect the system from potential damage and to ensure your personal safety:

- Electronic components in the game cabinet run on 115VAC 60Hz (230V/ 50Hz in most of Europe, the Middle East and the Far East delivered units).
- To help prevent electric shock, plug the system into a properly grounded power source. These cables are equipped with 3-prong plugs to help ensure proper grounding. Do not use adapter plugs or remove the grounding prong from a cable. If you must use an extension cable, use a 3-wire cable with properly grounded plugs.
- To help protect your system from sudden increases and decreases in electrical power, use a surge suppressor, line conditioner or Uninterruptible Power Supply (UPS).
- Be sure nothing rests on the system's cables and that the cables are not located where they can be stepped on or tripped over.
- Keep your system far away from radiators and other heat sources.
- Do not block cooling vents.

Precaution for Game Operation

Adrenaline Amusements Inc assumes no liability for injuries incurred while playing our games.

Operators should be aware that certain health and physical conditions may make people susceptible to injury when playing video games.

Chapter 1

Preface

Safety

Warning



To avoid electrical shock, unplug the cabinet before performing installation or service procedures.

If a power cord is damaged, it must be replaced by the equivalent power cord available from your distributor.



Adrenaline Amusement Inc assumes no liability for any damages or injuries incurred while setting up or servicing the cabinet. Only qualified service personnel should perform installation or service procedures.

Environmental Conditions

Cabinet is intended for indoor use only. Be sure to keep the cabinet dry and maintain operating temperatures of 59°-86° (15°-30°C).

Chapter 1

Preface

FCC Notices (United States)

Electromagnetic Interference (EMI) is any signal or emission radiated in free space or conducted along power or signal leads, that endangers the functioning of radio navigation or other safety service, or that seriously degrades, obstructs, or repeatedly interrupts a licensed radio communications service. Radio communications services include, but are not limited to, AM/FM commercial broadcast, television, cellular services, radar, air-traffic control, pager, and Personal Communication Services (PCS). These licensed services, along with unintentional radiators such as digital devices (Including computer systems) contribute to the electromagnetic environment.

Electromagnetic Compatibility (EMC) is the ability of items of electronic equipment to function properly together in the electronic environment. While this computer system has been designed and determined to be compliant with regulatory agency limits for EMI, there is no guarantee that interference will not occur in a particular installation. If this equipment does cause interference with radio communications services, which can be determined by turning the equipment off and on, you are encouraged to try to correct the interference by one or more of the following measures:

- Re-orient the receiving antenna
- Relocated the cabinet relative to the receiver
- Plug the game into a different outlet so that the computer and the receiver are on different branch circuits

If necessary, consult a Regulatory EMC representative of Adrenaline Amusements Inc or an experienced radio/television technician for additional suggestions. You may find the FCC interference Handbook to be helpful. It is available from the U.S. Government Print Office, Washington, DC 20402.

This device has been tested and complies with the limits for a Class A digital device pursuant to Part 15 of the FCC Rules. These limits are designed to provide reasonable protection against harmful interference when the equipment is operated in a commercial environment. This equipment generates, uses, and can radiate radio frequency energy. If not installed and used in accordance with the instruction manual, it may cause harmful interference with radio communications. Operation of this equipment in a residential area is likely to cause harmful interference, in which case you will be required to correct the interference at your own expense.

Operation is subject to following conditions:

- This device may not cause harmful interference.
- This device must accept any interference received, including interference that may cause undesired operation.

Chapter 2

Game Features

Hardware features

- Mini ITX INTEL computer
- 46" FULL HD LCD monitor
- Multitouch screen, detects 6 simultaneous touches

Cabinet FACTS

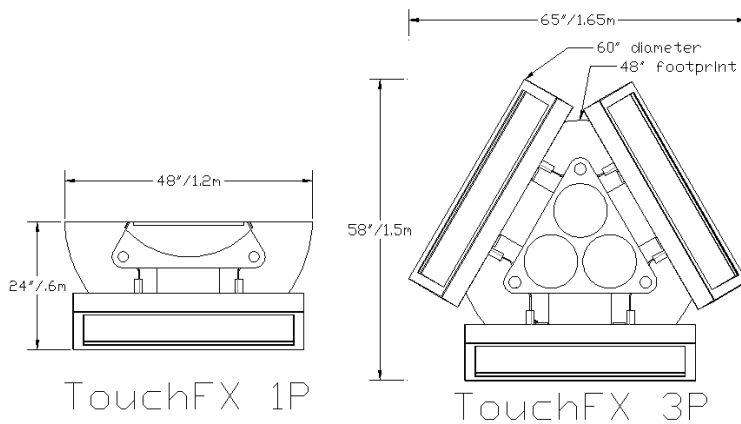

TouchFX 1P

TouchFX 3P

Height = 82" / 2.08m
Weight = 400 lbs / 180kg

Height = 91" / 2.31m
Weight = 900 lbs / 400kg

Voltage

TFX 1 Cabinet	
Voltage	Operating
115 VAC	5 AMP
220 VAC	2.5 AMP

TFX 3 Cabinet	
Voltage	Operating
115 VAC	15 AMP
220 VAC	7.5 AMP

Chapter 3

Machine Installation TFX3

1. Carefully remove the Cabinet from the shipping container giving yourself enough space.
2. Move the cabinet to the desired location
3. Some TFX3 are shipped in 2 parts, insert the top part. (see fig 1)
4. Insert the 3 fluorescent kits in the blue tubes (see fig 2)
5. Open the coin doors and plug in all 3 plugs from the fluorescent to the main power strip
6. Locate the power cord, you have 2 options: insert the power cord to the bottom of the machine to power it from a floor outlet or run an extension cable through one of the blue tube to power it from the ceiling.
7. Hang on screen to the support, insert the 4 bolts and then adjust to the desired height (normaly in the middle position). Do the same for all the other screens (fig 3)
8. Plug in the connectors between stand and screen (USB, Network, AC Power, and DC power)

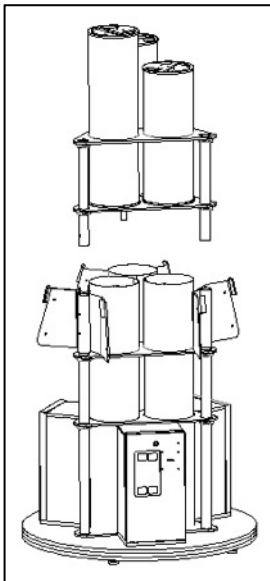

Fig. 1

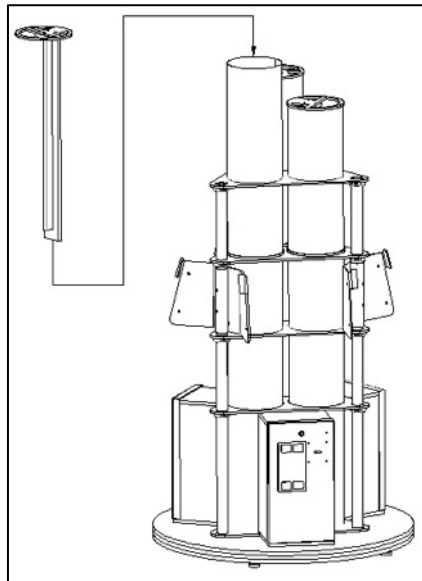

Fig. 2

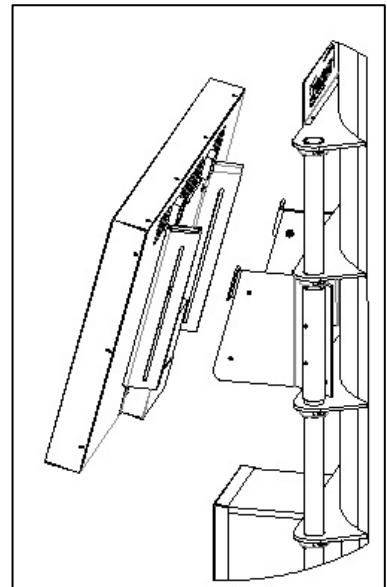

Fig. 3

Chapter 4

Operator Menu & Game Setup

This chapter describes how to use the Operator Control Panel to navigate through the Operator Main Menu to set up your product and adjust all the game play parameters.

The Operator Menu

To access the Operator Menu, use the Operator button located inside the coin door. This screen will appear.

To navigate the menu, press on the line you want to change then press the arrows to adjust the value.

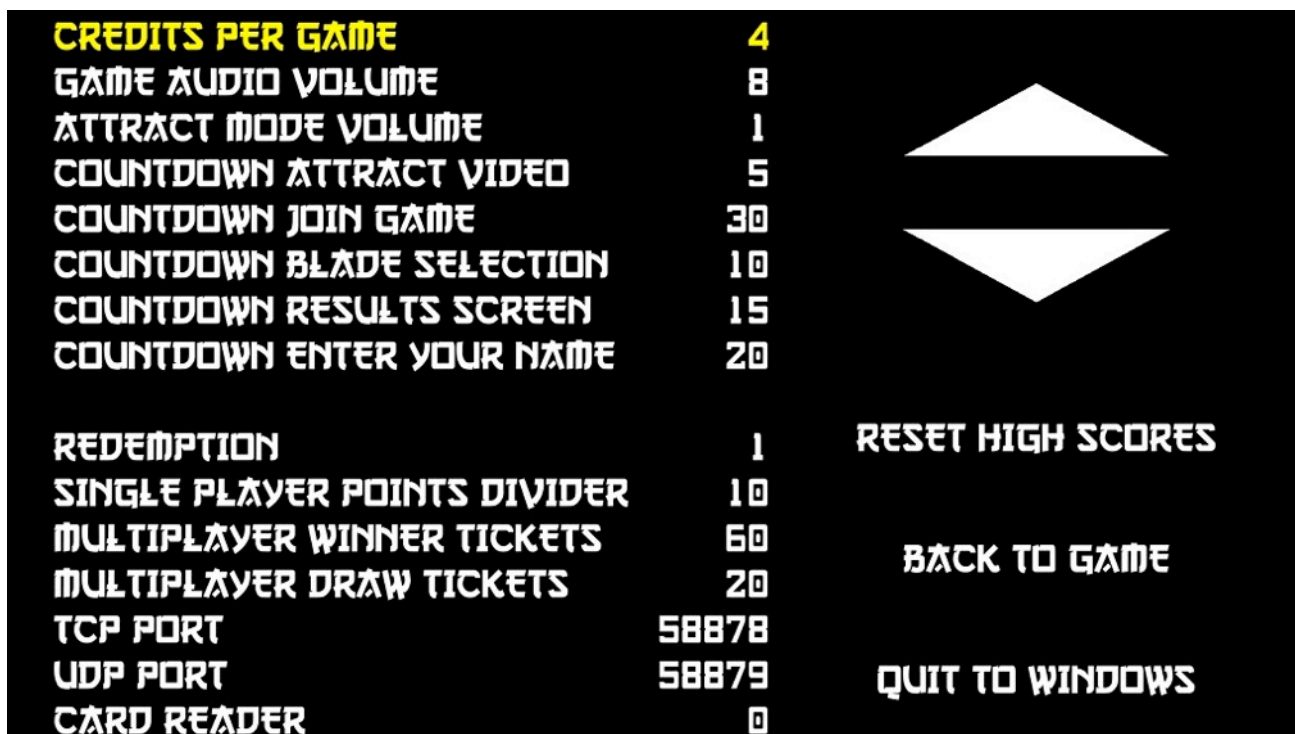

Chapter 4

Operator Menu	setting	What it is
Credits per Game	4	Credits required to play
Game Audio Volume	8	Adjust the audio volume in the game
Attract mode Volume	1	Adjust the audio volume of the attract mode
Countdown Attract video	5	Do not change
Countdown Join Game	30	Time to Join Multiplayer Game
Countdown Blade selection	10	Time for Blade selection screen Set to 0 to remove the menu
Countdown results screen	15	Time for results screen
Countdown enter your name	30	Timer for Enter Your Name screen
Redemption	1	0 to disable, 1 for ticket, 2 for Coupons
Single player points divider	10	Adjust payout tickets for single player game by dividing the score of the player by this value to determine amount of
Multiplayer winner tickets	60	Adjust the payout ticket for winner in multiplayer
Multiplayer draw tickets	20	Adjust payout for each player in a tie score game
Fixed Ticket Payout	0	Use a fix number of ticket instead of skill based
TCP Port	58878	Do not Change
UDP Port	58879	Do not change
Card Reader	0	Select 1 to display card swipe instead of credits
Time per Round	60	Adjust the length of the game in seconds
Redemption Unit Value	1	Value of the paper ticket
Japanese	0	To activate Japanese version

Chapter 5

Service & Repair

Computer connections ADR-11-1002

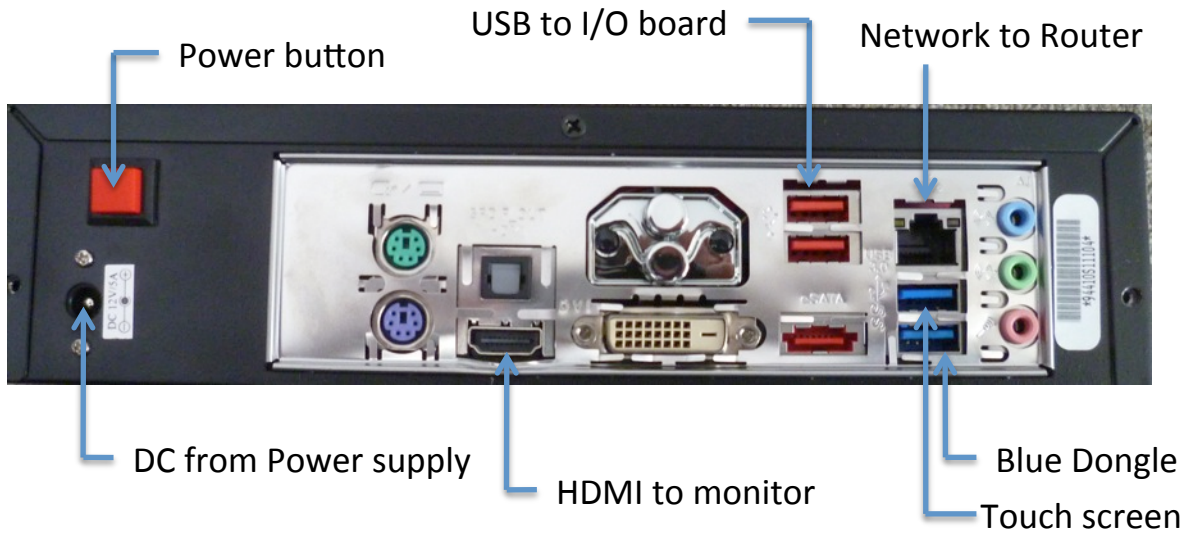

Touch screen troubleshooting and calibration

- Disconnect the USB cable between cabinet and screen, connect the keyboard. Press the letter Q, this should quit the game and fall back to the windows desktop. Disconnect the keyboard and connect the mouse. Double click on the Multitouch icon.

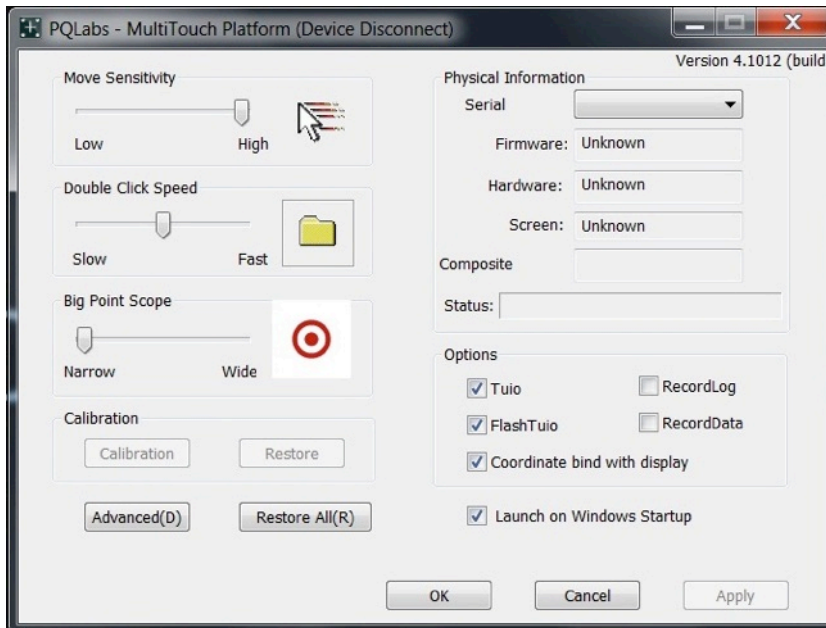

- **If window title screen says 'device disconnected'**
 - Check DC molex connection between cabinet and monitor. With a volt meter check if you have 5V on red and black wire coming from cabinet. If not check DC power supply accessible from the coin door located in the center of the cabinet.
 - If 5V is ok, Remove monitor bezel and computer bottom cover (see chapter 6) and check USB connection between computer and touch screen. Also check if round barrel connection is ok for DC power to touch screen.
- **If window title screen says "device connected"**
 - Click on calibration then follow the onscreen instructions. If touchscreen does not respond as expected during calibration go to next step
 - Click on advanced, OK, then 'Reset TouchData'. It will ask you to wait 10 seconds then click on yes. When done retry calibration.

Troubleshooting- Windows boot error

At machine start up if you get a windows error message

“Windows boot manager”

The boot selection failed because a required device is inaccessible.

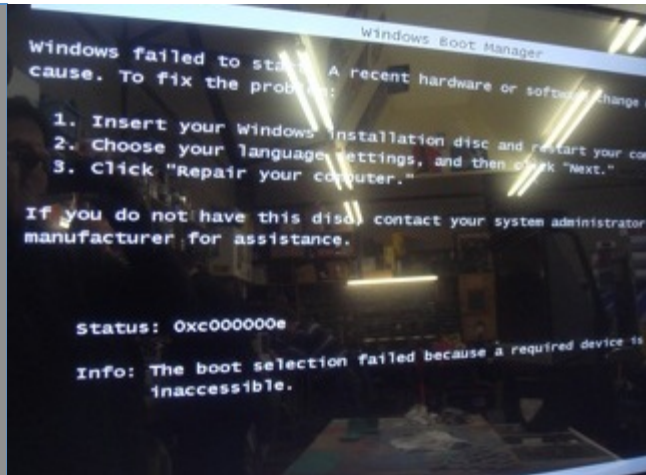

What you are required to do

- Disconnect the usb cable between cabinet and screen, connect the keyboard.
- Disconnect power and reconnect to restart computer.
- Press F8 repeatedly until you get to the windows boot selection
- If you get to a blue boot disk selection press Enter then press again on F8 repeatedly until you get to the windows boot selection
- Select Normal boot then press Enter.
- Disconnect keyboard and reconnect USB connection

Chapter 5

Troubleshooting

Video Troubleshooting

No picture and no audio	Power Problem, check the power to monitor
	loose or faulty connections between Monitor and computer, make sure HDMI cable is connected properly to both computer and LCD monitor
	No power to computer, Verify the computer is ON by the blue LED on the top of the computer. Remove computer bottom cover and press the RED power button. Make sure that the round power plug is well connected. Check LED on Computer external power supply. Check AC power cord to computer external power supply
	Bios setting has changed, If the computer does not power automatically when machine is powered on, check BIOS settings AC Power on function is set to Power ON

Audio Troubleshooting

Low volume	Increase the volume in the game by pressing the operator button and adjust
	Increase volume of the monitor by using the remote control

Error Message Screens

Error when opening serial port	Check that USB cable is connected from computer to I/O board.
--------------------------------	---

Chapter 5

Fluorescent tube replacement (TFX3)

- Open the coin door and unplug the power cable of the Fluorescent assembly
- With a step ladder, lift the fluorescent assemblies from inside the blue tubes
- To replace the bottom fluorescent, remove the top bolt on each gray tube as indicated by the arrows on figure 2. then with the 2 persons lift up, and remove the top part. You will then have access to the bottom fluorescents.

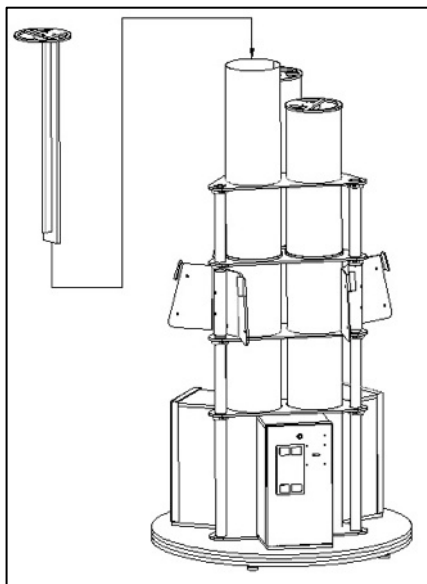

Fig. 1

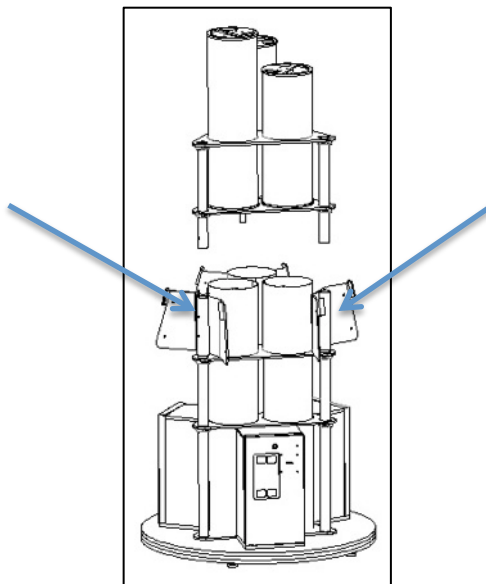
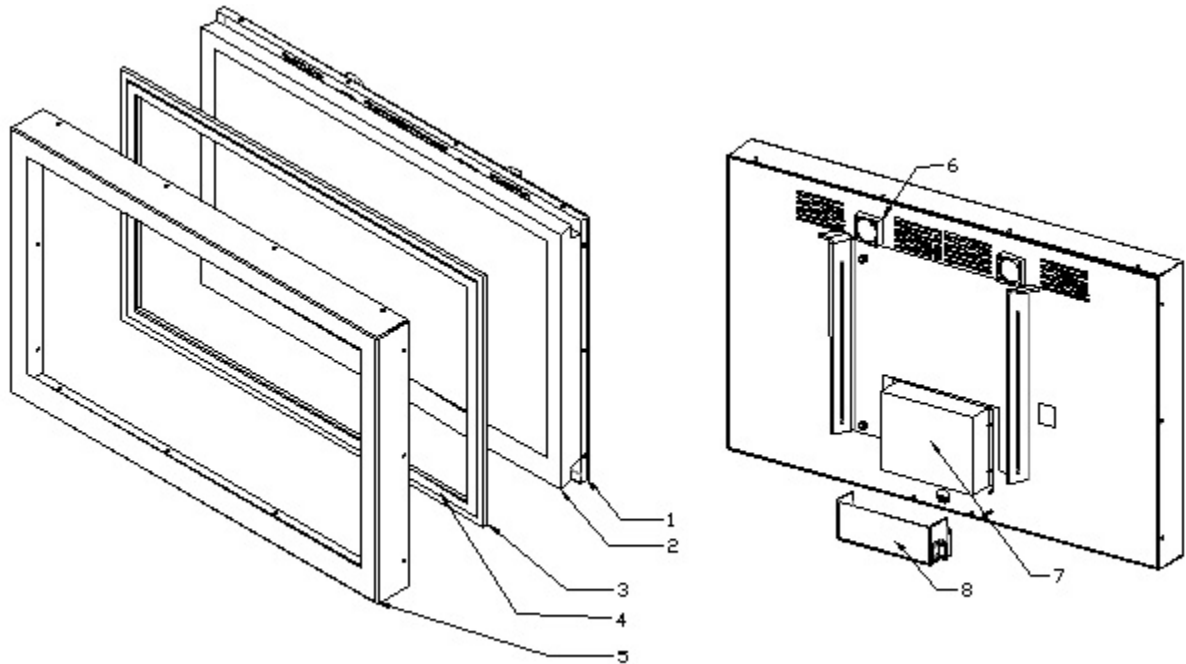

Fig. 2

Chapter 5

Replacement Parts

Screen Assembly TF-00-1010



REF	PART	NUMBER
1	Monitor back frame	TF-01-1020
2	46" Monitor	ADR-10-1001
3	Tempered Glass	TF-10-1220
4	46" Touch screen frame	ADR-10-1002
5	Monitor front frame	TF-01-1030
6	Cooling fan	TF-05-1250
7	TouchFX Computer	ADR-11-1002
8	Computer back cover	TF-01-1040

Chapter 5

Door Assembly TF-00-1020

REF	PART	NUMBER
1	Door Panel	KA-01-1130-00
2	Coin acceptor	ADR-10-001-00
3	Ticket feeder	Ka-01-1140-00
4	Blank panel for coin acceptor (optional)	KA-04-001-00

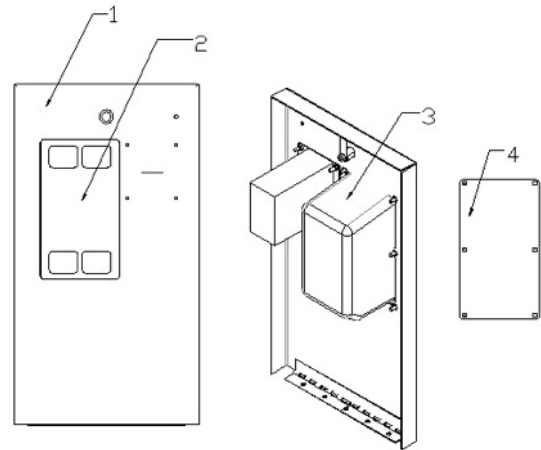

Chapter 6

I/O board TF-04-1200

REF	Link
J4	To operator button
J8	Not used
J6	To low ticket switch
J10	To ticket dispenser
J11	To coin door and meters

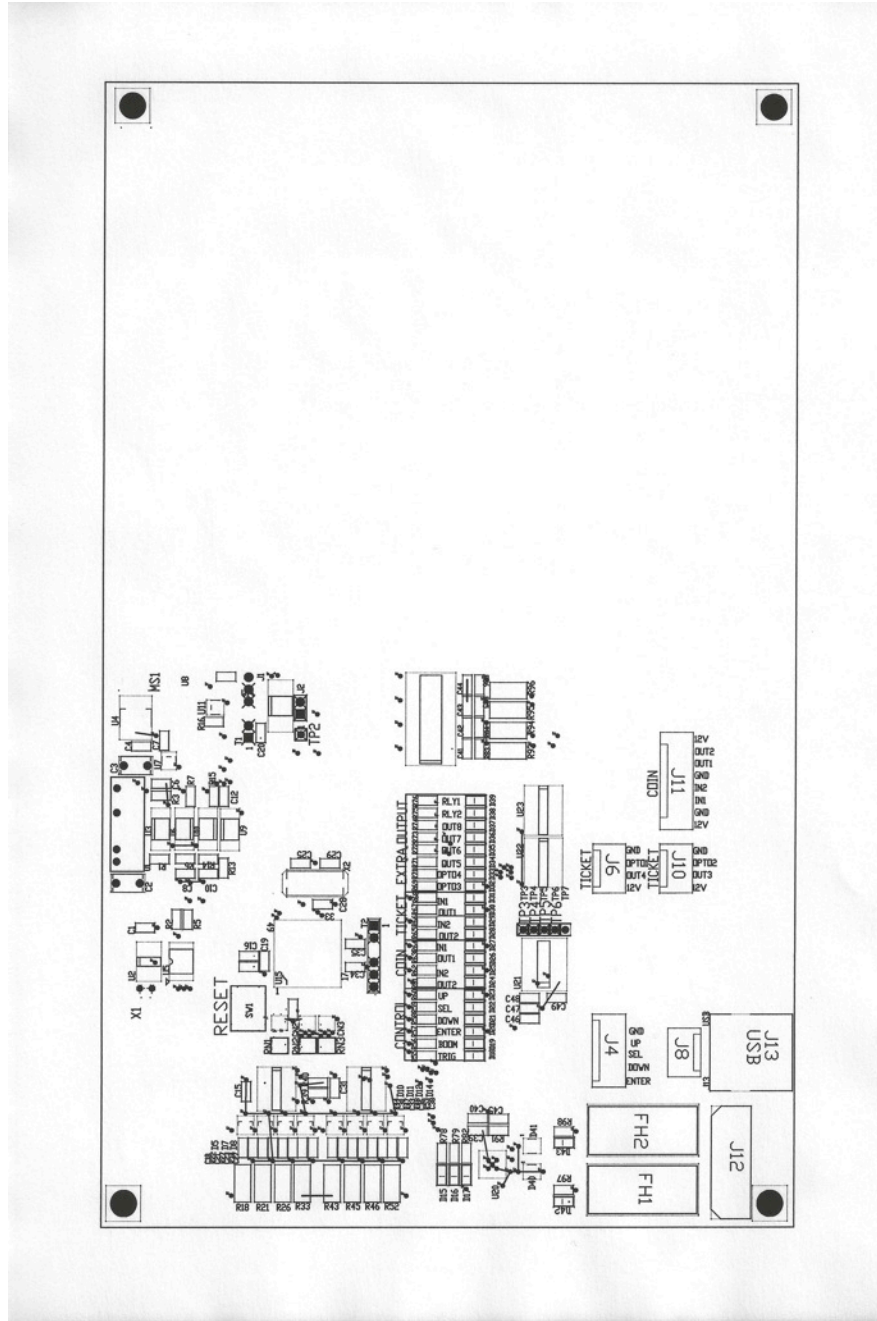

Chapter 6

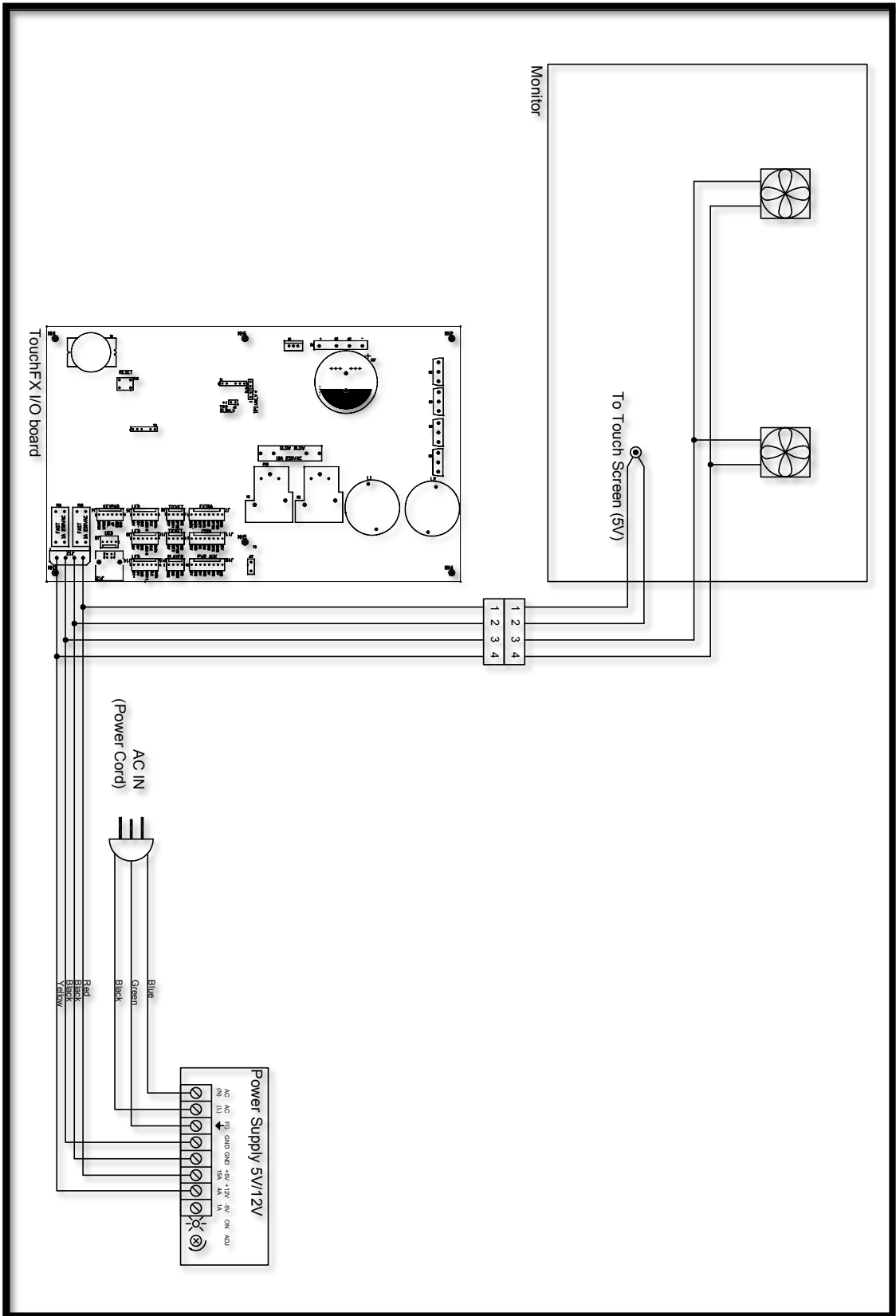

Chapter 6

